

FEATURES

- Constant 500kHz Switching Frequency
- Uses All Surface Mount Components
- Operates with Inputs as Low as 4V
- Saturated Switch Design (0.3Ω)
- Cycle-by-Cycle Current Limiting
- Easily Synchronizable
- Inductor Size as Low as 2μH
- Shutdown Current: 20μA

APPLICATIONS

- Portable Computers
- Battery-Powered Systems
- Battery Charger
- Distributed Power

DESCRIPTION

The LT[®]1507 is a 500kHz monolithic buck mode switching regulator, functionally identical to the LT1375 but optimized for lower input voltage applications. It will operate over a 4V to 15V input range, compared with 5.5V to 25V for the LT1375. A 1.5A switch is included on the die along

with all the necessary oscillator, control and logic circuitry. High switching frequency allows a considerable reduction in the size of external components. The topology is current mode for fast transient response and good loop stability. Both fixed output voltage (3.3V) and adjustable parts are available.

A special high speed bipolar process and new design techniques allow this regulator to achieve high efficiency at a high switching frequency. Efficiency is maintained over a wide output current range by keeping quiescent supply current to 4mA and by utilizing a supply boost capacitor to allow the NPN power switch to saturate. A shutdown signal will reduce supply current to 20μA. The LT1507 can be externally synchronized from 570kHz to 1MHz with logic level inputs.

The LT1507 fits into standard 8-pin SO and PDIP packages. Temperature rise is kept to a minimum by the high efficiency design. Full cycle-by-cycle short-circuit protection and thermal shutdown are provided. Standard surface mount external parts are used including the inductor and capacitors.

LT, LTC and LT are registered trademarks of Linear Technology Corporation.

TYPICAL APPLICATION

5V to 3.3V Volt Down Converter

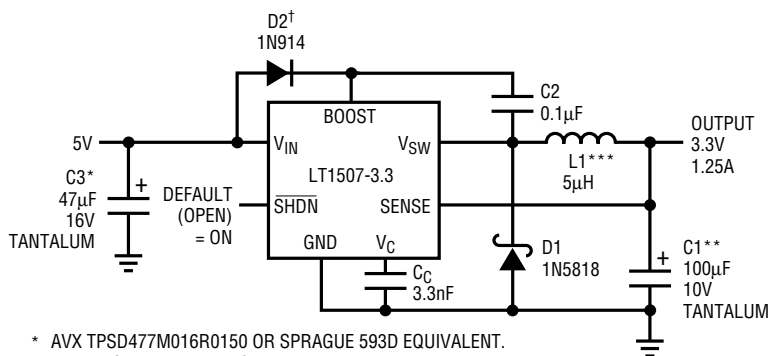

* AVX TPSD477M016R0150 OR SPRAGUE 593D EQUIVALENT. RIPPLE CURRENT RATING \geq 0.6A

** AVX TPSD108M010R0100 OR SPRAGUE 593D EQUIVALENT

*** COILTRONICS CTX5-1. SUBSTITUTION UNITS SHOULD BE RATED AT \geq 1.25A, USING LOW LOSS CORE MATERIAL

† SEE BOOST PIN CONSIDERATIONS IN APPLICATIONS INFORMATION SECTION FOR ALTERNATIVE D2 CONNECTION

5V to 3.3V Efficiency

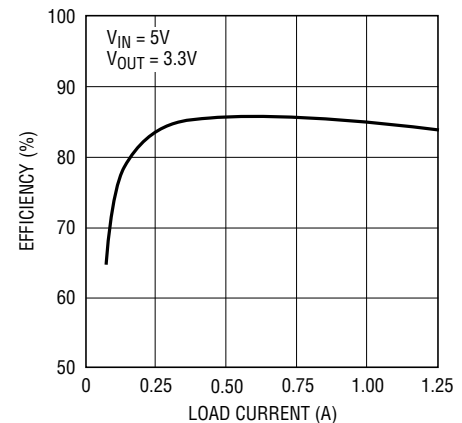

LT1507 • TA02

ABSOLUTE MAXIMUM RATINGS

Input Voltage	16V
Boost Pin Voltage	25V
Shutdown Pin Voltage	7V
FB Pin Voltage (Adjustable Part)	3.5V
FB Pin Current (Adjustable Part)	1mA
Sense Voltage (Fixed 3.3V Part)	5V
Sync Pin Voltage	7V
Operating Ambient Temperature Range	
LT1507C	0°C to 70°C
LT1507I	-40°C to 85°C
Max Operating Junction Temperature	125°C
Storage Temperature Range	-65°C to 150°C
Lead Temperature (Soldering, 10 sec)	300°C

PACKAGE/ORDER INFORMATION

<p>TOP VIEW</p> <p>N8 PACKAGE: 8-LEAD PDIP S8 PACKAGE: 8-LEAD PLASTIC SO</p> <p>$T_{JMAX} = 125^{\circ}C, \theta_{JA} = 80^{\circ}C/W$ TO $120^{\circ}C/W$ (N) $T_{JMAX} = 125^{\circ}C, \theta_{JA} = 120^{\circ}C/W$ TO $170^{\circ}C/W$ (S) DEPENDING ON PC BOARD LAYOUT</p>	ORDER PART NUMBER
	LT1507CN8 LT1507CN8-3.3 LT1507CS8 LT1507CS8-3.3 LT1507IN8 LT1507IN8-3.3 LT1507IS8 LT1507IS8-3.3
	S8 PART MARKING
	1507 1507I 15073 1507I3

Consult factory for Military grade parts.

ELECTRICAL CHARACTERISTICS

$T_J = 25^{\circ}C, V_{IN} = 5V, V_C = 1.5V$, boost open, switch open unless otherwise specified.

PARAMETER	CONDITIONS	MIN	TYP	MAX	UNITS		
Reference Voltage (Adjustable)	All Conditions	●	2.39	2.42	2.45	V	
		●	2.36		2.48	V	
Sense Voltage (3.3V)	All Conditions	●	3.25	3.3	3.35	V	
		●	3.23		3.37	V	
Sense Pin Resistance		●	4.0	6.6	9.5	k Ω	
Reference Voltage Line Regulation	$4.3V \leq V_{IN} \leq 15V$	●		0.01	0.03	%/V	
FB Input Bias Current		●		0.5	2	μA	
Error Amplifier Voltage Gain (Note 8)	(Note 1)		150	400			
Error Amplifier Transconductance (Note 8)	$\Delta I(V_C) = \pm 10\mu A$	●	1500	2000	2700	μmho	
		●	1100		3000	μmho	
V_C Pin to Switch Current Transconductance			2		A/V		
Error Amplifier Source Current	$V_{FB} = 2.1V$ or $V_{SENSE} = 2.9V$	●	150	225	320	μA	
Error Amplifier Sink Current	$V_{FB} = 2.7V$ or $V_{SENSE} = 3.7V$			2		mA	
V_C Pin Switching Threshold	Duty Cycle = 0			0.9		V	
V_C Pin High Clamp	$V_{FB} = 2.1V$ or $V_{SENSE} = 2.9V$			2.1		V	
Switch Current Limit	V_C Open, $V_{FB} = 2.1V$ or $V_{SENSE} = 2.9V$ $V_{IN} \geq 5V, V_{BOOST} = V_{IN} + 5V$	DC $\leq 50\%$	●	1.50	2	3	A
		DC = 80%	●	1.35		3	A
Switch On Resistance (Note 6)	$I_{SW} = 1.5A, V_{BOOST} = V_{IN} + 5V$	●		0.3	0.4	Ω	
		●			0.5	Ω	
Maximum Switch Duty Cycle	$V_{FB} = 2.1V$ or $V_{SENSE} = 2.9V$	●	90	93		%	
		●	86	93		%	

ELECTRICAL CHARACTERISTICS

$T_J = 25^\circ\text{C}$, $V_{IN} = 5\text{V}$, $V_C = 1.5\text{V}$, boost open, switch open unless otherwise specified.

PARAMETER	CONDITIONS		MIN	TYP	MAX	UNITS	
Switch Frequency	V_C Set to Give 50% Duty Cycle $-25^\circ\text{C} \leq T_J \leq 125^\circ\text{C}$ $T_J \leq -25^\circ\text{C}$		460 440 440	500	540 560 570	kHz kHz kHz	
Switch Frequency Line Regulation	$4.3\text{V} \leq V_{IN} \leq 15\text{V}$		●	0.05	0.15	%/V	
Frequency Shifting Threshold on F_B Pin	$\Delta f = 10\text{kHz}$		●	0.8	1.0	1.3	V
Minimum Input Voltage (Note 2)			●	4	4.3	V	
Minimum Boost Voltage (Note 3)	$I_{SW} \leq 1.5\text{A}$		●	3	3.5	V	
Boost Current (Note 4)	$V_{BOOST} = V_{IN} + 5\text{V}$	$I_{SW} = 500\text{mA}$, $-25^\circ\text{C} \leq T_J \leq 125^\circ\text{C}$ $T_J \leq -25^\circ\text{C}$ $I_{SW} = 1.5\text{A}$, $-25^\circ\text{C} \leq T_J \leq 125^\circ\text{C}$ $T_J \leq -25^\circ\text{C}$		12 25	22 25 35 40	mA mA mA mA	
Input Supply Current (Note 5)			●	3.8	5.4	mA	
Shutdown Supply Current	$V_{SHDN} = 0\text{V}$, $V_{IN} \leq 12\text{V}$ $V_{SW} = 0\text{V}$, V_C Open		●	15	50	μA μA	
Lockout Threshold	V_C Open		●	2.3	2.38	2.46	V
Shutdown Threshold	V_C Open	Device Shutting Down Device Starting Up	● ●	0.15 0.25	0.37 0.45	0.70 0.70	V V
Minimum Synchronizing Amplitude			●	1.5	2.2	V	
Synchronizing Frequency Range (Note 7)				580	1000	kHz	

The ● denotes specifications which apply over the operating temperature range.

Note 1: Gain is measured with a V_C swing equal to 200mV above the low clamp level to 200mV below the upper clamp level.

Note 2: Minimum input voltage is not measured directly, but is guaranteed by other tests. It is defined as the voltage where internal bias lines are still regulated, so that the reference voltage and oscillator frequency remain constant. Actual minimum input voltage to maintain a regulated output will depend on output voltage and load current. See Applications Information.

Note 3: This is the minimum voltage across the boost capacitor needed to guarantee full saturation of the internal power switch.

Note 4: Boost current is the current flowing into the BOOST pin with the pin held 5V above input voltage. It flows only during switch ON time.

Note 5: Input supply current is the bias current drawn by the V_{IN} pin when the SHDN pin is held at 1V (switching disabled).

Note 6: Switch ON resistance is calculated by dividing V_{IN} to V_{SW} voltage by the forced current (1.5A). See Typical Performance Characteristics for the graph of switch voltage at other currents.

Note 7: For synchronizing frequency above 700kHz, with duty cycles above 50%, external slope compensation may be needed. See Applications Information.

Note 8: Transconductance and voltage gain refer to the internal amplifier exclusive of the voltage divider. To calculate gain and transconductance refer to SENSE pin on fixed voltage parts. Divide values shown by the ratio $V_{OUT}/2.42$.

TYPICAL PERFORMANCE CHARACTERISTICS

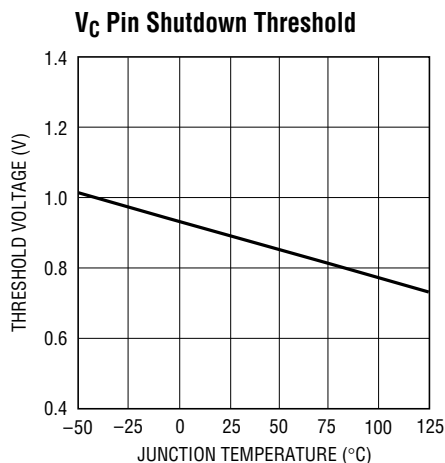

LT1507 • TPC01

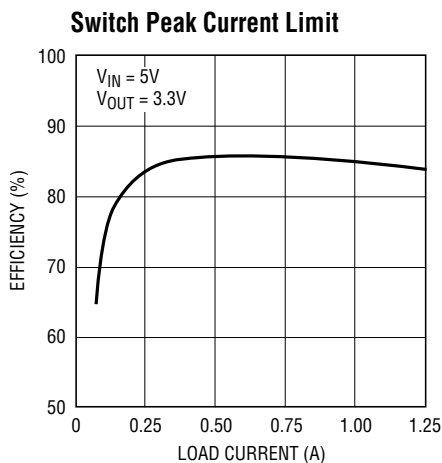

LT1507 • TA02

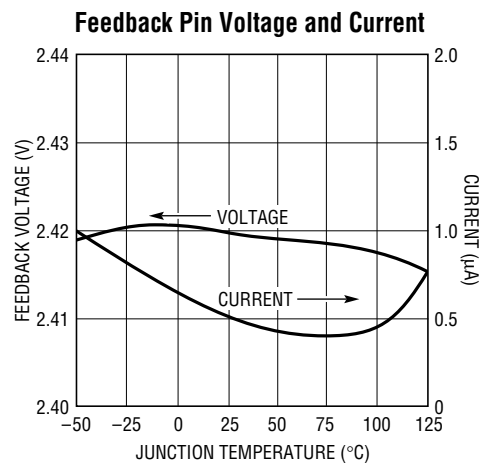

LT1507 • TPC03

TYPICAL PERFORMANCE CHARACTERISTICS

Shutdown Pin Bias Current

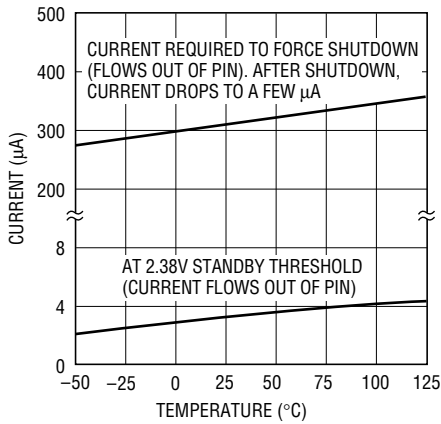

LT1507 • TPC04

Standby and Shutdown Thresholds

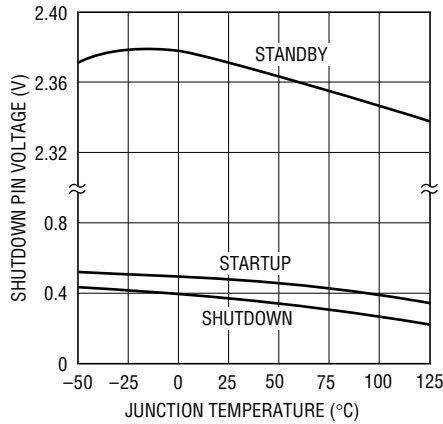

LT1507 • TPC05

Shutdown Supply Current

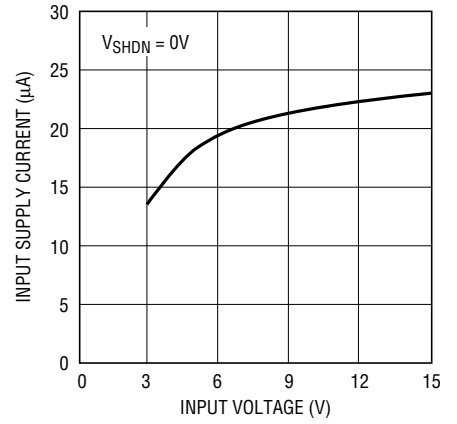

LT1507 • TPC06

Shutdown Supply Current

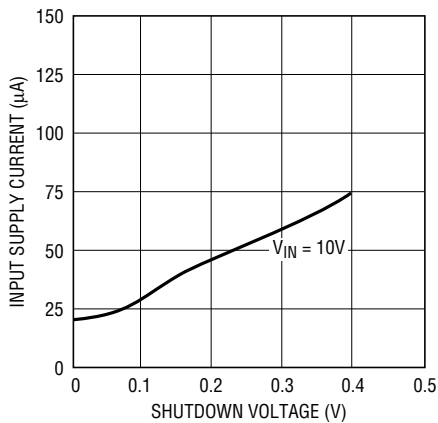

LT1507 • TPC07

Error Amplifier Transconductance

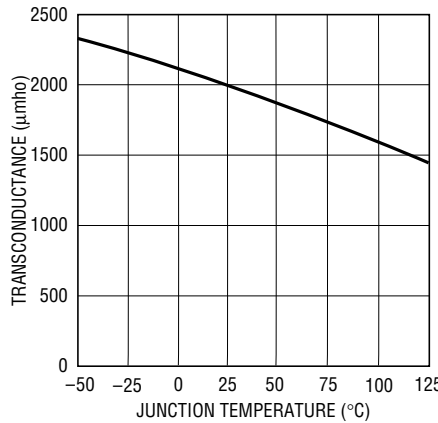

LT1507 • TPC08

Error Amplifier Transconductance

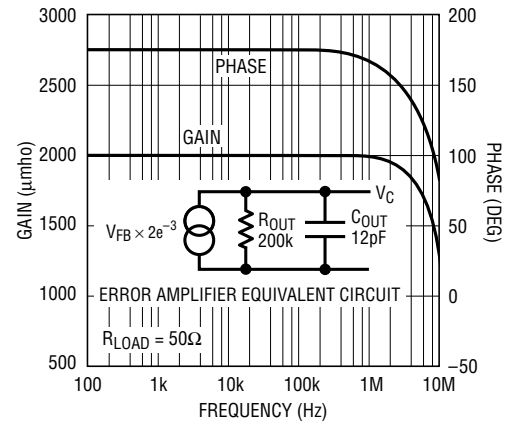

LT1507 • TPC09

Frequency Foldback

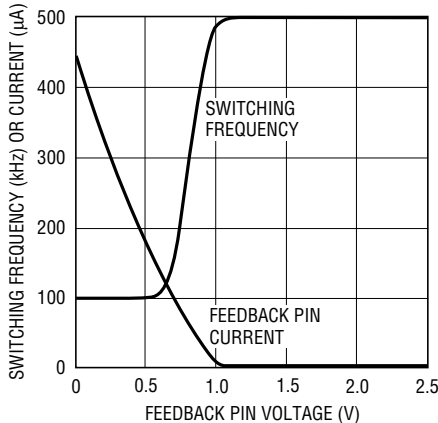

LT1507 • TPC10

Switching Frequency

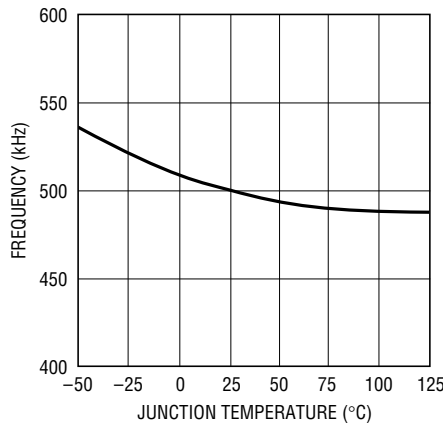

LT1507 • TPC11

Minimum Input Voltage with 3.3V Output

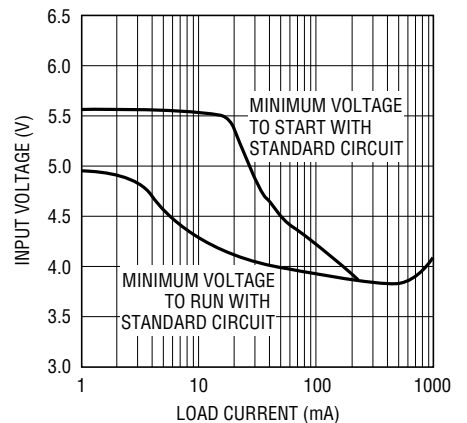

LT1507 • TPC12

MINIMUM INPUT VOLTAGE CAN BE REDUCED BY ADDING A SMALL EXTERNAL PNP. SEE APPLICATIONS INFORMATION

TYPICAL PERFORMANCE CHARACTERISTICS

Current Limit Foldback

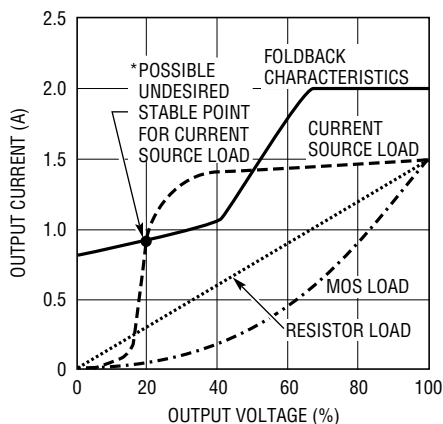

LT1507 • TPC13

*SEE "MORE THAN JUST VOLTAGE FEEDBACK" IN APPLICATIONS INFORMATION SECTION

Maximum Load Current at $V_{OUT} = 3.3V$

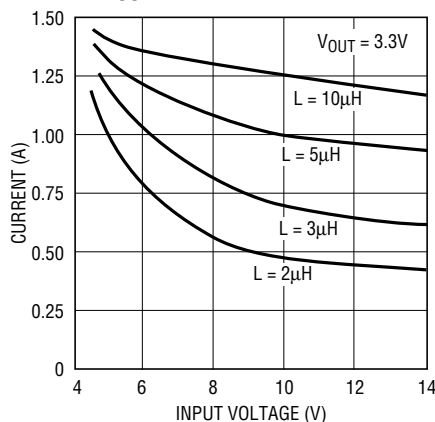

LT1507 • TPC14

Maximum Load Current at $V_{OUT} = 5V$

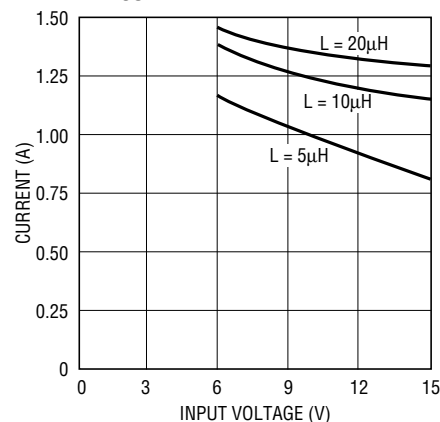

LT1507 • TPC15

Boost Pin Current

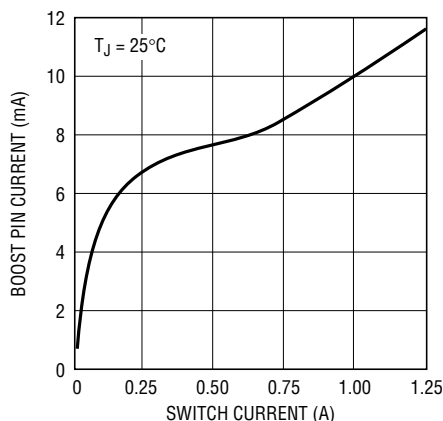

LT1507 • TPC16

Inductor Core Loss for 3.3V Output

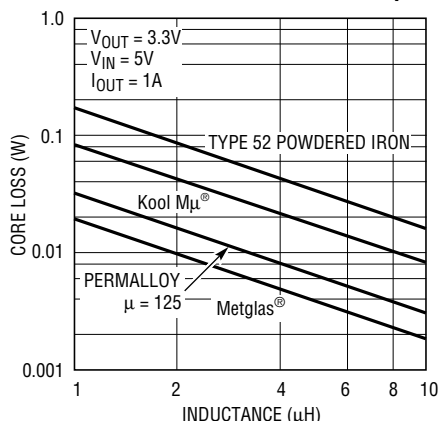

LT1507 • TPC17

CORE LOSS IS INDEPENDENT OF LOAD CURRENT UNTIL LOAD CURRENT FALLS LOW ENOUGH FOR CIRCUIT TO GO INTO DISCONTINUOUS MODE

Switch Voltage Drop

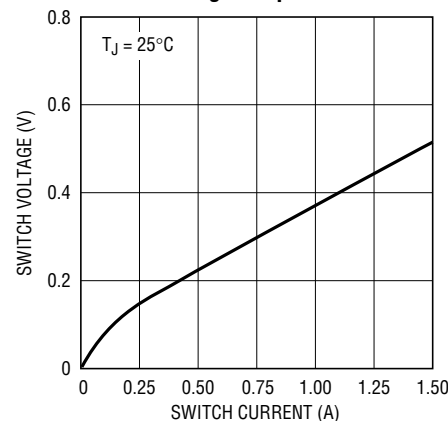

LT1507 • TPC18

Kool M μ is a registered trademark of Magnetics, Incorporated.
Metglas is a registered trademark of AlliedSignal Incorporated.

PIN FUNCTIONS

BOOST (Pin 1): The BOOST pin is used to provide a drive voltage, higher than the input voltage, to the internal bipolar NPN power switch. Without this added voltage the typical switch voltage loss would be about 1.5V. The additional boost voltage allows the switch to saturate and voltage loss approximates that of a 0.3Ω FET structure, but with a much smaller die area. Efficiency improves from

70% for conventional bipolar designs to greater than 85% for these new parts.

V_{IN} (Pin 2): Input Pin. The LT1507 is designed to operate with an input voltage between 4.5V and 15V. Under certain conditions, input voltage may be reduced down to 4V. Actual minimum operating voltage will always be higher than the output voltage. It may be limited by switch

PIN FUNCTIONS

saturation voltage and maximum duty cycle. A typical value for minimum input voltage is 1V above output voltage. Start-up conditions may require more voltage at light loads. See Minimum Input Voltage for details.

V_{SW} (Pin 3): The switch pin is driven up to the input voltage in the ON state and is an open circuit in the OFF state. At higher load currents, pin voltage during the off condition will be one diode drop below ground as set by the external catch diode. At lighter loads the pin will assume an intermediate state equal to output voltage during part of the switch OFF time. Maximum *negative* voltage on the switch pin is 1V with respect to the GND pin, so it must always be clamped with a catch diode to the GND pin.

SHDN (Pin 4): The shutdown pin is used to turn off the regulator and to reduce input drain current to a few microamperes. Actually this pin has two separate thresholds, one at 2.38V to disable switching and a second at 0.4V to force complete micropower shutdown. The 2.38V threshold functions as an accurate undervoltage lockout (UVLO). This is sometimes used to prevent the regulator from delivering power until the input voltage has reached a predetermined level.

SYNC (Pin 5): The SYNC pin is used to synchronize the internal oscillator to an external signal. It is directly logic compatible and can be driven with any signal between 10% and 90% duty cycle. The synchronizing range is equal to *initial* operating frequency up to 1MHz. See Synchronizing section for details.

FB/SENSE (Pin 7): The feedback pin is used to set output voltage using an external voltage divider that generates 2.42V at the pin with the desired output voltage. The fixed voltage (–3.3V) parts have the divider included on the chip and the feedback pin is used as a sense pin connected directly to the 5V output. Two additional functions are performed by the feedback pin. When the pin voltage drops below 1.7V, switch current limit is reduced. Below 1V, switching frequency is also reduced. See More Than Just Voltage Feedback.

V_C (Pin 8): The V_C pin is the output of the error amplifier and the input of the peak switch current comparator. It is normally used for frequency compensation but can do double duty as a current clamp or control loop override. This pin sets at about 1V for very light loads and 2V at maximum load. It can be driven to ground to shut off the regulator, but if driven high, current must be limited to 4mA.

BLOCK DIAGRAM

The LT1507 is a constant frequency, current mode buck converter. This means that there is an internal clock and two feedback loops that control the duty cycle of the power switch. In addition to the normal error amplifier, there is a current sense amplifier that monitors switch current on a cycle-by-cycle basis. A switch cycle starts with an oscillator pulse which sets the RS flip-flop to turn the switch on. When switch current reaches a level set by the inverting input of the comparator, the flip-flop is reset and the switch turns off. Output voltage control is obtained by using the output of the error amplifier to set the switch current trip point. This technique means that the error amplifier commands current to be delivered to the output rather than voltage. A voltage fed system will have low phase shift up to the resonant frequency of the inductor

and output capacitor, then an abrupt 180° shift will occur. The current fed system will have 90° phase shift at a much lower frequency, but will not have the additional 90° shift until well beyond the LC resonant frequency. This makes it much easier to frequency compensate the feedback loop and also gives much quicker transient response.

High switch efficiency is attained by using the BOOST pin to provide a voltage to the switch driver which is higher than the input voltage, allowing the switch to be saturated. This boosted voltage is generated with an external capacitor and diode.

Two comparators are connected to the shutdown pin. One has a 2.38V threshold for undervoltage lockout and the second has a 0.4V threshold for complete shutdown.

BLOCK DIAGRAM

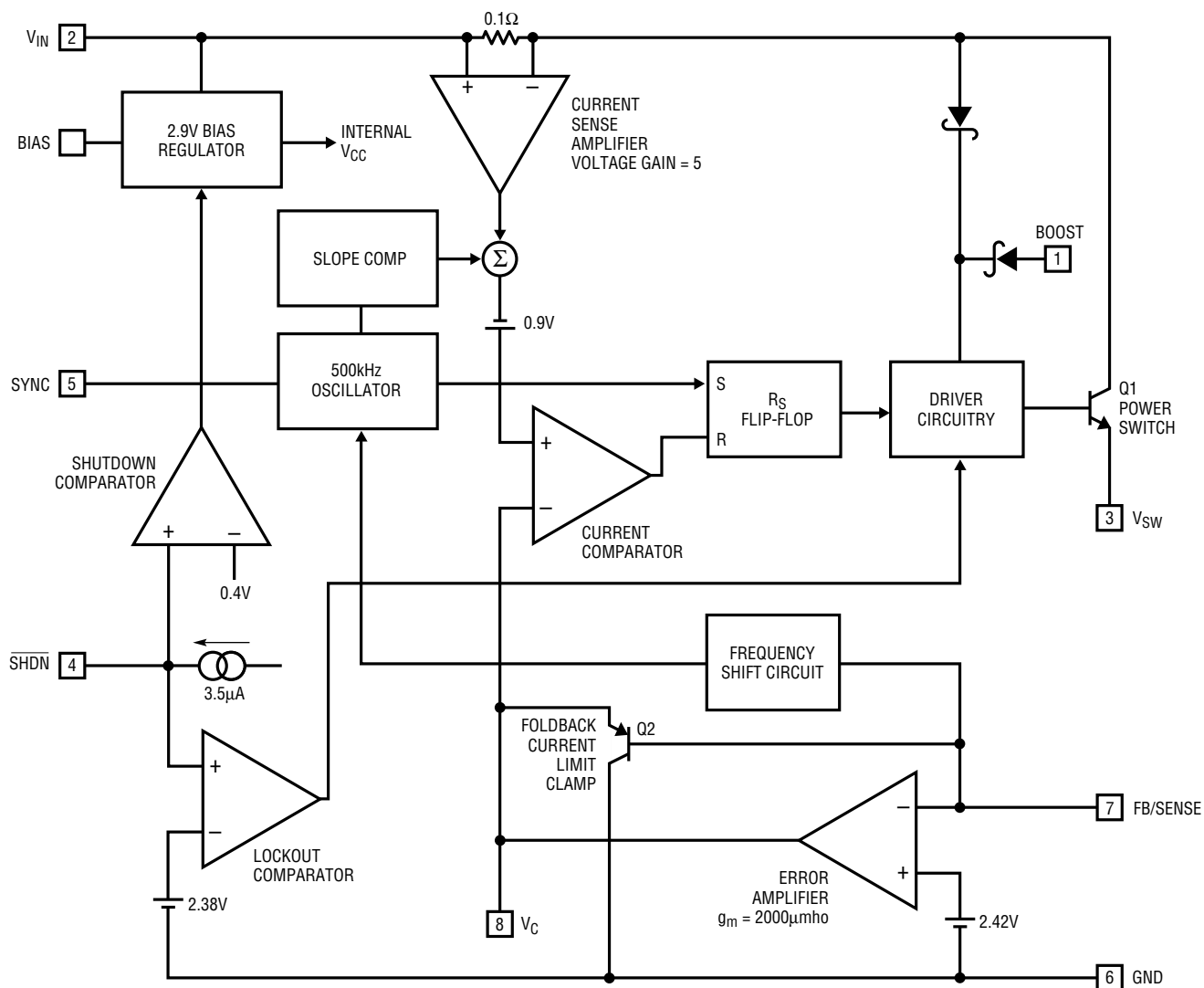

LT1507 • BD

Figure 1. Block Diagram

APPLICATIONS INFORMATION

Note: This application section is adapted from the more complete version found in the LT1375/LT1376 data sheet. If more details are desired consult the LT1375/LT1376 Applications Information section, but please acquaint yourself thoroughly with this LT1507 information first so that differences between the LT1375 and the LT1507 do not cause confusion.

FEEDBACK PIN FUNCTIONS

The feedback pin (FB or SENSE) on the LT1507 is used to set output voltage and also to provide several overload protection features. The first part of this section deals with selecting resistors to set output voltage and the remaining part talks about foldback frequency and current limiting created by the FB pin. Please read both parts before

APPLICATIONS INFORMATION

committing to a final design. The fixed 3.3V LT1507-3.3 has internal divider resistors and the FB pin is renamed SENSE, connected directly to the output.

The suggested value for the output divider resistor from FB to ground (R2) is 5k or less and the formula for R1 is shown below. The output voltage error caused by ignoring the input bias current on the FB pin is less than 0.25% with R2 = 5k. Please read below if R2 is increased above the suggested value.

$$R1 = \frac{R2(V_{OUT} - 2.42)}{2.42}$$

More Than Just Voltage Feedback

The feedback pin is used for more than just output voltage sensing. It also reduces switching frequency and current limit when output voltage is very low (see graph in Typical Performance Characteristics). This is done to control power dissipation in both the IC and in the external diode and inductor during short-circuit conditions. A shorted output requires the switching regulator to operate at very low duty cycles and the average current through the diode and inductor is equal to the short-circuit current limit of the switch (typically 2A of the LT1507, folding back to less than 1A). Minimum switch ON time limitations would prevent the switcher from attaining a sufficiently low duty cycle if switching frequency were maintained at 500kHz, so frequency is reduced by about 5:1 when the feedback

pin voltage drops below 1V (see Frequency Foldback graph). This does not affect operation with normal load conditions; one simply sees a gear shift in switching frequency during start-up as the output voltage rises.

In addition to lower switching frequency, the LT1507 also operates at lower switch current limit when the feedback pin voltage drops below 1.5V. This *foldback current limit* greatly reduces power dissipation in the IC, diode and inductor during short-circuit conditions. Again, it is nearly transparent to the user under normal load conditions. The only loads which may be affected are current source loads which maintain full-load current with output voltage less than 50% of final value. In these rare situations, the feedback pin can be clamped above 1.5V with an external diode to defeat foldback current limit. *Caution:* clamping the feedback pin means that frequency shifting will also be defeated, so a combination of high input voltage and dead shorted output may cause the LT1507 to lose control of current limit.

The internal circuitry which forces reduced switching frequency also causes current to flow out of the feedback pin when output voltage is low. If the FB pin falls below 1V, current begins to flow out of the pin and reduces frequency at the rate of approximately 5kHz/μA. To ensure adequate frequency foldback (under worst-case short-circuit conditions) the external divider Thevinin resistance must be low enough to pull 150μA out of the FB pin with 0.6V on the

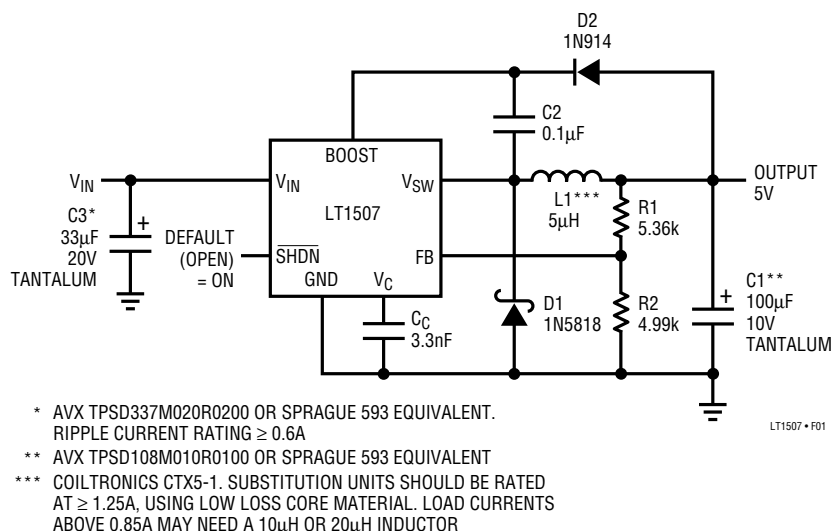

Figure 2. Typical Schematic for LT1507 Adjustable Application

APPLICATIONS INFORMATION

pin ($R_{DIV} = R1/R2 \leq 4k$). The net result is that reductions in frequency and current limit are affected by output voltage divider impedance. Although divider impedance is not critical, caution should be used if resistors are increased beyond the suggested values and short-circuit conditions will occur with high input voltage. High frequency pickup will also increase and the protection accorded by frequency and current foldback will decrease.

CHOOSING THE INDUCTOR AND OUTPUT CAPACITOR

For most applications the value of the inductor will fall in the range of $2\mu H$ to $10\mu H$. Lower values are chosen to reduce physical size of the inductor. Higher values allow more output current because they reduce peak current seen by the LT1507 switch, which has a 1.5A limit. Higher values also reduce output ripple voltage and reduce core loss. Graphs in the Typical Performance Characteristics section show maximum output load current versus inductor size and input voltage. A second graph shows core loss versus inductor size for various core materials.

When choosing an inductor you might have to consider maximum load current, core and copper losses, allowable component height, output voltage ripple, EMI, fault current in the inductor, saturation and, of course, cost. The following procedure is suggested as a way of handling these somewhat complicated and conflicting requirements.

1. Choose a value in microhenries from the graphs of Maximum Load Current and Inductor Core Loss for 3.3V Output. If you want to double check that the chosen inductor *value* will allow sufficient load current, go to the next section, Maximum Output Load Current. Choosing a small inductor with lighter loads may result in discontinuous mode of operation, but the LT1507 is designed to work well in either mode. Keep in mind that lower core loss means higher cost, at least for closed-core geometries like toroids. Type 52 powdered iron, Kool M μ and Molypermalloy are old standbys for toroids in ascending order of price. A newcomer, Metglas, gives very low core loss with high saturation current.

Assume that the average inductor current is equal to load current and decide whether or not the inductor must withstand continuous fault conditions. If maximum load current is 0.5A, for instance, a 0.5A inductor

may not survive a continuous 1.5A overload condition. Dead shorts ($V_{OUT} \leq 1V$) will actually be more gentle on the inductor because the LT1507 has foldback current limiting (see graph in Typical Performance Characteristics).

2. Calculate peak inductor current at full load current to ensure that the inductor will not saturate. Peak current can be significantly higher than output current, especially with smaller inductors and lighter loads, so don't omit this step. Powdered iron cores are forgiving because they saturate softly, whereas ferrite cores saturate abruptly. Other core materials fall in between somewhere. The following formula assumes a continuous mode of operation, but it errs only slightly on the high side for discontinuous mode, so it can be used for all conditions.

$$I_{PEAK} = I_{OUT} + \frac{V_{OUT}(V_{IN} - V_{OUT})}{2(f)(L)(V_{IN})}$$

V_{IN} = Maximum input voltage

f = Switching frequency = 500kHz

3. Decide if the design can tolerate an "open" core geometry like ferrite rods or barrels, which have high magnetic field radiation or whether it needs a closed core like a toroid to prevent EMI problems. One would not want an open core next to a magnetic storage media for instance! This is a tough decision because the rods or barrels are temptingly cheap and small and there are no helpful guidelines to calculate when the magnetic field radiation will be a problem. The following is an example of just how subtle the "B" field problems can be with open geometry cores.

We had selected an open drum shaped ferrite core for the LTC1376 demonstration board because the inductor was extremely small and inexpensive. It met all the requirements for current and the ferrite core gave low core loss. When the boards came back from assembly, many of them had somewhat higher than expected output ripple voltage. We removed the inductors and output capacitors and found them to be no different than the good boards. After much head scratching and hours of delicate low level ripple measurements on the good and bad boards, I realized that the problem must

APPLICATIONS INFORMATION

be due to a radiated magnetic field coupling into PC board traces. But why were some boards bad and others good? In a moment of desperation (or divine inspiration) I unsoldered a “bad” inductor, rotated it 180° and resoldered it. Problem fixed!!

It turns out that the inductor was symmetrical in all regards except that the polarity of the magnetic field reversed when the unit was rotated 180° because current flowed in the opposite direction in the coil. In one direction, the magnetically induced ripple in the board traces *added* to output ripple. Rotating the inductor caused the induced field to *reduce* output ripple. Unfortunately the inductor had no physical package assymetry to indicate rotation, including part marking, so we had to visually examine the winding in each unit before soldering it to the boards. This little horror story should not preclude the use of open core inductors, but it emphasizes the need to carefully check the effect these seductively small, low cost inductors may have on regulator or system performances.

4. Look for an inductor (see Table 1) which meets the requirements of core shape, peak current (to avoid saturation), average current (to limit heat) and fault current (if the inductor gets too hot, wire insulation will melt and cause turn-to-turn shorts). Keep in mind that all good things like high efficiency, surface mounting, low profile and high temperature operation will increase cost, sometimes dramatically.
5. After making an initial choice, consider secondary things like output voltage ripple, second sourcing, etc. Use the experts in the Linear Technology Applications Department if you feel uncertain about the final choice. They have experience with a wide range of inductor types and can tell you about the latest developments in low profile, surface mounting, etc.

Table 1. Representative Surface Mount Units

MANUFACTURER	VALUE (μH)	DC (A)	CORE TYPE	SERIES (Ω)	CORE	HEIGHT (mm)
Coiltronics						
CTX5-1	5	2.3	Tor	0.027	KMμ	4.2
CTX10-1	10	1.9	Tor	0.039	KMμ	4.2
CTX5-1P	5	1.8	Tor	0.021	52	4.2
CTX10-1P	10	1.6	Tor	0.030	52	4.2
Sumida						
CDRH64	10	1.7	SC	0.084	Fer	4.5
CDRH73	10	1.7	SC	0.055	Fer	3.4
CD73	10	1.4	Open	0.062	Fer	3.5
CD104	10	2.4	Open	0.041	Fer	4.0
Gowanda						
SM20-102K	10	1.3	Open	0.038	Fer	7
Dale						
IHSM-4825	10	3.1	Open	0.071	Fer	5.6
IHSM-5832	10	4.3	Open	0.053	Fer	7.1

SC = Semi-closed geometry

Fer = Ferrite core material

52 = Type 52 powdered iron core material

KMμ = Kool Mμ

OUTPUT CAPACITOR

The output capacitor is normally chosen by its effective series resistance (ESR), because that is what determines output ripple voltage. At 500kHz any polarized capacitor is essentially resistive. To get low ESR takes *volume*; physically larger capacitors have lower ESR. The ESR range needed for typical LT1507 applications is 0.05Ω to 0.5Ω. A typical output capacitor is an AVX type TPS, 100μF at 10V, with a guaranteed ESR less than 0.1Ω. This is a “D” size surface mount solid tantalum capacitor. TPS capacitors are specially constructed and tested for low ESR so they give the lowest ESR for a given volume. The value in microfarads is not particularly critical and values from 22μF to greater than 500μF work well, but you cannot cheat mother nature on ESR. If you find a tiny 22μF solid tantalum capacitor, it will have high ESR and output ripple voltage will be terrible. The chart in Table 2 shows some typical solid tantalum surface mount capacitors.

APPLICATIONS INFORMATION

Table 2. Surface Mount Solid Tantalum Capacitor ESR and Ripple Current

E CASE SIZE	ESR (MAX Ω)	RIPPLE CURRENT (A)
AVX TPS, Sprague 593D	0.1 to 0.3	0.7 to 1.1
AVX TAJ	0.7 to 0.9	0.4
D CASE SIZE		
AVX TPS, Sprague 593D	0.1 to 0.3	0.7 to 1.1
AVX TAJ	0.9 to 2.0	0.36 to 0.24
C CASE SIZE		
AVX TPS	0.2 (Typ)	0.5 (Typ)
AVX TAJ	1.8 to 3.0	0.22 to 0.17

Many engineers have heard that solid tantalum capacitors are prone to failure if they undergo high surge currents. This is historically true, and type TPS capacitors are specially tested for surge capability, but surge ruggedness is not a critical issue with the *output* capacitor. Solid tantalum capacitors fail during very high *turn-on* surges which do not occur at the output of regulators. High *discharge* surges, such as when the regulator output is dead shorted, do not harm the capacitors.

Unlike the input capacitor, RMS ripple current in the output capacitor is normally low enough that ripple current rating is not an issue. The current waveform is triangular with a typical value of 200mA RMS. The formula to calculate this is:

Output Capacitor Ripple Current (RMS)

$$I_{\text{RIPPLE}}(\text{RMS}) = \frac{0.29(V_{\text{OUT}})(V_{\text{IN}} - V_{\text{OUT}})}{(L)(f)(V_{\text{IN}})}$$

Ceramic Capacitors

Higher value, lower cost ceramic capacitors are now becoming available in smaller case sizes. These are tempting for switching regulator use because of their very low ESR. Unfortunately, the ESR is so low that it can cause loop stability problems when ceramic is used for the output capacitor. Solid tantalum capacitor ESR generates a loop “zero” at 5kHz to 50kHz that is instrumental in giving acceptable loop phase margin. Ceramic capacitors remain capacitive to beyond 300kHz and usually resonate with their ESL before ESR becomes effective. They are

appropriate for input bypassing because of their high ripple current ratings and tolerance of turn-on surges.

OUTPUT RIPPLE VOLTAGE

Ripple voltage is determined by the high frequency impedance of the output capacitor and ripple current through the inductor. Ripple current is triangular (continuous mode) with a peak-to-peak value of:

$$I_{\text{P-P}} = \frac{(V_{\text{OUT}})(V_{\text{IN}} - V_{\text{OUT}})}{(V_{\text{IN}})(L)(f)}$$

Output ripple voltage is also triangular with peak-to-peak amplitude of:

$$V_{\text{RIPPLE}} = (I_{\text{P-P}})(\text{ESR}) \text{ (peak-to-peak)}$$

Example: with $V_{\text{IN}} = 5\text{V}$, $V_{\text{OUT}} = 3.3\text{V}$, $L = 5\mu\text{H}$, $\text{ESR} = 0.1\Omega$;

$$I_{\text{P-P}} = \frac{(3.3)(5 - 3.3)}{5 \left[5 \left(10^{-6} \right) \right] \left[500 \left(10^3 \right) \right]} = 0.45_{\text{P-P}}$$

$$V_{\text{RIPPLE}} = (0.45\text{A})(0.1\Omega) = 45\text{mV}_{\text{P-P}}$$

MAXIMUM OUTPUT LOAD CURRENT

Maximum load current will be less than the 1.5A rating of the LT1507, especially with lower inductor values. Inductor ripple current must be taken into account as well as reduced switch current at high duty cycles. Maximum *switch current* rating (I_{P}) of the LT1507 is 1.5A up to 50% duty cycle (DC), decreasing to 1.35A at 80% duty cycle, shown graphically in Typical Performance Characteristics and as a formula below. Current rating decreases with duty cycle because the LT1507 has internal slope compensation to prevent current mode subharmonic switching. For more details on subharmonic oscillation read Application Note 19. Peak guaranteed switch current (I_{P}) is found from:

$$I_{\text{P}} = 1.5\text{A for } \frac{V_{\text{OUT}}}{V_{\text{IN}}} \leq 0.5$$

$$I_{\text{P}} = 1.75\text{A} - \frac{0.5(V_{\text{OUT}})}{V_{\text{IN}}} \text{ for } \frac{V_{\text{OUT}}}{V_{\text{IN}}} \geq 0.5$$

APPLICATIONS INFORMATION

Example: with $V_{OUT} = 3.3V$, $V_{IN} = 5V$;

$$V_{OUT}/V_{IN} = 3.3/5 = 0.67$$

$$I_P = 1.75 - (0.5)(0.66) = 1.42A$$

Maximum load current would be equal to maximum switch current *for an infinitely large inductor*, but with finite inductor size, maximum load current is reduced by one half peak-to-peak inductor current. The following formula assumes continuous mode operation; the term on the right must be less than one half of I_P .

Continuous mode:

$$I_{OUT(MAX)} = I_P - \frac{(V_{OUT})(V_{IN} - V_{OUT})}{2(L)(f)(V_{IN})}$$

For the conditions above, with $L = 5\mu H$ and $f = 500kHz$;

$$I_{OUT(MAX)} = 1.42 - \frac{(3.3)(5 - 3.3)}{2[5(10^{-6})][500(10^3)]5}$$

$$= 1.42 - 0.22 = 1.2A$$

At $V_{IN} = 8V$, $V_{OUT}/V_{IN} = 0.41$, so I_P is equal to 1.5A and $I_{OUT(MAX)}$ is equal to:

$$1.5 - \frac{(3.3)(8 - 3.3)}{2[5(10^{-6})][500(10^3)]8}$$

$$= 1.5 - 0.39 = 1.11A$$

Note that there is less load current available at the higher input voltage because inductor ripple current increases. This is not always the case. Certain combinations of inductor value and input voltage range may yield lower available load current at the lowest input voltage due to reduced peak switch current at high duty cycles. If load current is close to the maximum available, please check maximum available current at both input voltage extremes. To calculate actual peak switch current with a given set of conditions, use:

$$I_{SWITCH(PEAK)} = I_{OUT} + \frac{V_{OUT}(V_{IN} - V_{OUT})}{2(L)(f)(V_{IN})}$$

For lighter loads where discontinuous mode operation can be used, maximum load current is equal to:

Discontinuous mode:

$$I_{OUT(MAX)} = \frac{(I_P)^2(f)(L)(V_{IN})}{2(V_{OUT})(V_{IN} - V_{OUT})}$$

Example: with $L = 2\mu H$, $V_{OUT} = 5V$ and $V_{IN(MAX)} = 15V$;

$$I_{OUT(MAX)} = \frac{(1.5)^2[500(10^3)][2(10^{-6})]15}{2(5)(15 - 5)}$$

$$= 338mA$$

The main reason for using such a tiny inductor is that it is physically very small, but keep in mind that peak-to-peak inductor current will be very high. This will increase output ripple voltage. If the output capacitor has to be made larger to reduce ripple voltage, the overall circuit could actually be larger.

CATCH DIODE

The suggested catch diode (D1) is a 1N5818 Schottky or its Motorola equivalent, MBR130. It is rated at 1A average forward current and 30V reverse voltage. Typical forward voltage is 0.42V at 1A. The diode conducts current only during switch OFF time. Peak reverse voltage is equal to regulator input voltage. Average forward current in normal operation can be calculated from:

$$I_{D(AVG)} = \frac{I_{OUT}(V_{IN} - V_{OUT})}{V_{IN}}$$

This formula will not yield values higher than 1A with maximum load current of 1.25A unless the ratio of input to output voltage exceeds 5:1. The only reason to consider a larger diode is the worst-case condition of a high input voltage and *overloaded* (not shorted) output. Under short-circuit conditions, foldback current limit will reduce diode current to less than 1A, but if the output is overloaded and does not fall to less than 1/3 of nominal output voltage, foldback will not take effect. With the overloaded condition, output current will increase to a typical value of 1.8A, determined by peak switch current limit of 2A. With $V_{IN} = 10V$, $V_{OUT} = 2V$ (3.3V overloaded) and $I_{OUT} = 1.8A$:

$$I_{D(AVG)} = \frac{1.8(10 - 2)}{10} = 1.44A$$

APPLICATIONS INFORMATION

This is safe for short periods of time, but it would be prudent to check with the diode manufacturer if continuous operation under these conditions must be tolerated.

BOOST PIN CONSIDERATIONS

For most applications, the boost components are a 0.22 μ F capacitor and an MBR0520 or BAT85 Schottky diode. This capacitor value is twice that suggested for the LT1376 because the lower voltages commonly found in LT1507 applications may require lower ripple voltage across the capacitor to ensure adequate boost voltage under worst-case conditions. Efficiency is not affected by the capacitor value, but the capacitor should have an ESR of less than 2 Ω to ensure that it can be recharged fully under the worst-case condition of minimum input voltage. Almost any type of film or ceramic capacitor will work fine.

The anode of the diode can be connected to the regulated output voltage or the unregulated input voltage. The “boost voltage” generated across the boost capacitor is then nearly identical to the anode voltage. The input connection minimizes start-up problems and gives plenty of boost voltage, but efficiency is slightly lower, especially with input voltages above 10V. For 5V to 3.3V operation, or any output voltage less than 3.3V, the diode should be connected to the input. With input voltage more than 3V above the output and an output voltage of at least 3.3V the output connection will give better efficiency. Use the BAT85 Schottky diode for 3.3V applications where the anode is connected to the output.

LAYOUT CONSIDERATIONS

Suggested layout for the LT1507 is shown in Figure 3. The main concern for layout is to minimize the length of the

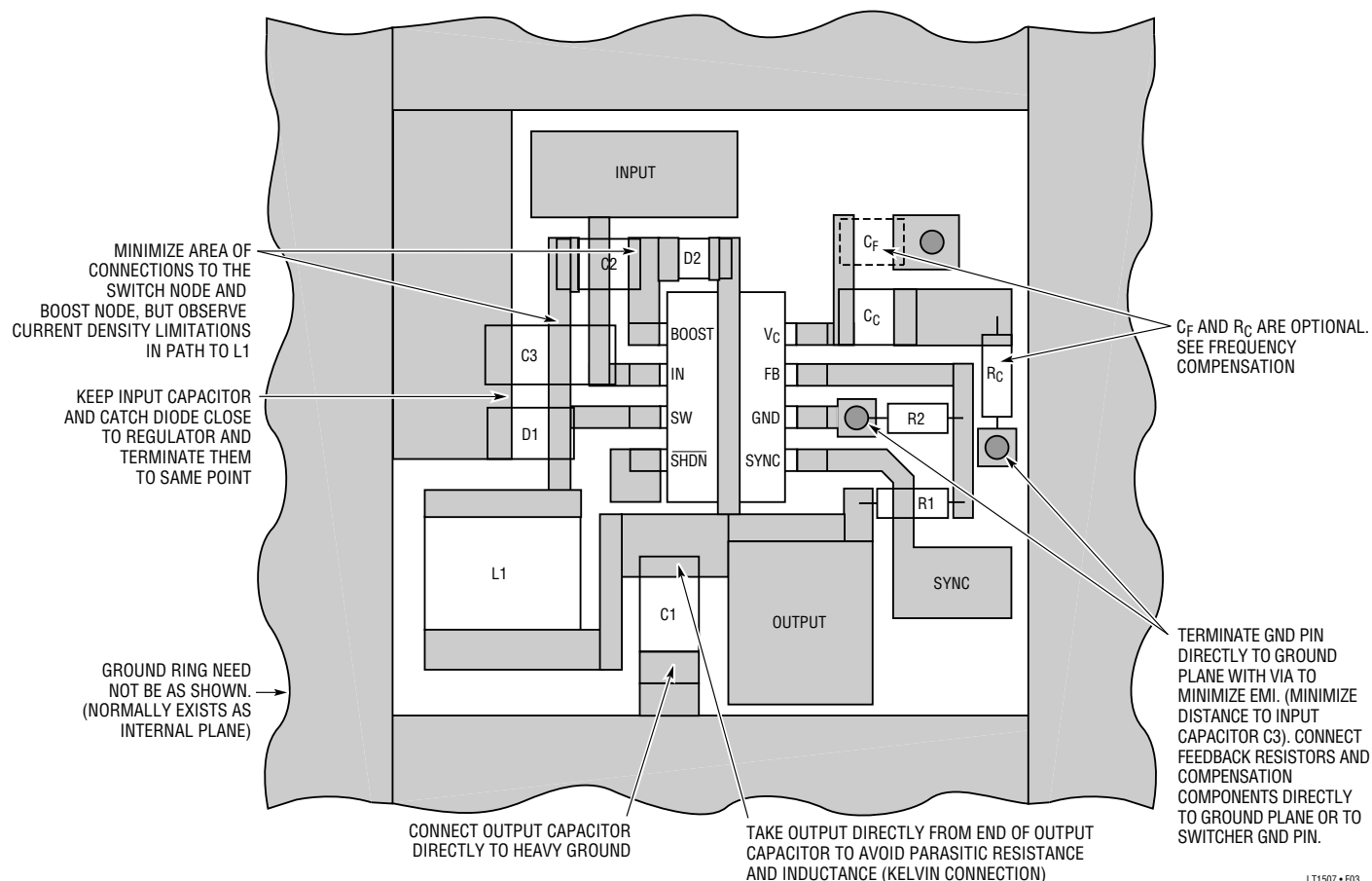

Figure 3. Suggested Layout

APPLICATIONS INFORMATION

high speed circulating current path shown in Figure 4 and to make connections to the output capacitor in a manner that minimizes output ripple and noise. For more details, see Applications Information section in the LT1376 data sheet.

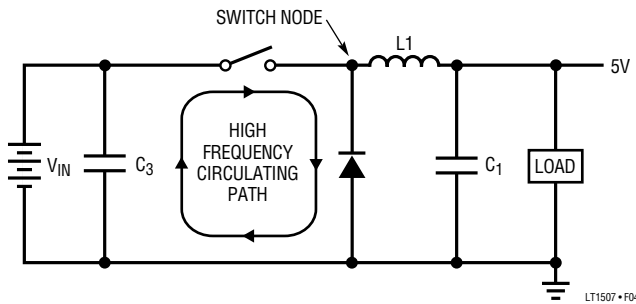

Figure 4. High Speed Switching Path

INPUT BYPASSING AND VOLTAGE RANGE

Input Bypass Capacitor

Stepdown converters draw current from the input supply in pulses. The average height of these pulses is equal to load current and the duty cycle is equal to V_{OUT}/V_{IN} . Rise and fall time of the current is very fast. A local bypass capacitor across the input supply is necessary to ensure proper operation of the regulator and minimize the ripple current fed back into the input supply. *The capacitor also forces switching current to flow in a tight local loop, minimizing EMI.*

Do not cheat on the ripple current rating of the input bypass capacitor, but also don't get hung up on the value in microfarads. The input capacitor is intended to absorb all the switching current ripple, which can have an RMS value as high as one half of load current. Ripple current ratings on the capacitor must be observed to ensure reliable operation. The actual value of the capacitor in microfarads is not particularly important because at 500kHz, any value above $5\mu\text{F}$ is essentially resistive. Ripple current rating is the critical parameter. RMS ripple current can be calculated from:

$$I_{\text{RIPPLE}}(\text{RMS}) = I_{\text{OUT}} \sqrt{\frac{V_{\text{OUT}}(V_{\text{IN}} - V_{\text{OUT}})}{V_{\text{IN}}^2}}$$

The term inside the radical has a maximum value of 0.5 when input voltage is twice output and stays near 0.5 for a relatively wide range of input voltages. It is common practice, therefore, to simply use the worst-case value and assume that RMS ripple current is one half of load current. At maximum output current of 1.5A for the LT1507, the input bypass capacitor should be rated at 0.75A ripple current. Note however, that there are many secondary considerations in choosing the final ripple current rating. These include ambient temperature, average versus peak load current, equipment operating schedule and required product lifetime. For more details see Application Notes 19 and 46.

Input Capacitor Type

Some caution must be used when selecting the type of capacitor used at the input of regulators. Aluminum electrolytics are lowest cost, but are physically large to achieve adequate ripple current rating, and size constraints (especially height) may preclude their use. Ceramic capacitors are now available in larger values and their high ripple current and voltage rating make them ideal for input bypassing. Cost is slightly higher and footprint may also be somewhat larger. Solid tantalum capacitors are a good choice except that they have a history of occasional spectacular failures when they are subjected to very large current surges during power-up. The capacitors can short and then burn with a brilliant white light and lots of nasty smoke. This phenomenon occurs in only a small percentage of units, but it has led some OEM companies to forbid their use in high surge applications. The input bypass capacitor of regulators can see such high surges when a battery or high capacitance source is connected.

Several manufacturers have developed a line of solid tantalum capacitors specially tested for surge capability (AVX TPS series for instance, see Table 2). Even these units may fail if the input current surge exceeds a value equal to the voltage rating of the capacitor divided by 1Ω (10A for a 10V capacitor). For this reason, AVX recommends using the highest voltage rating possible for the input capacitor. *For equal case size*, this means that lower values of capacitance must be used. As stated above, this

APPLICATIONS INFORMATION

is not a problem, but it should be noted that for *equal case size*, the ripple current rating and ESR of higher voltage capacitors will be somewhat worse. The lower input operating voltages of the LT1507 allow considerable derating of capacitor voltage. If solid tantalum units are used, it would be wise to use units rated at 25V or more, as long as ripple current requirements are met. Design Note 122 discusses the problem of showing typical input capacitor surges that occur when batteries or adapters are hot plugged to typical regulator systems.

A new capacitor type known as OS-CON uses a “semiconductor” dielectric to achieve extremely low ESR and high ripple current rating. These are ideal for input bypassing because they are not surge sensitive. They are not suggested for output capacitors because the very low ESR may present loop stability problems. Price and size (height) are issues to be considered. The original manufacturer is Sanyo but there are now additional sources.

Larger capacitors may be necessary when the input voltage is very close to the minimum specified on the data sheet. A 5 μ F ceramic input capacitor for instance, moves at about 0.1V/ μ s during switch ON time when load current is 1A, creating a ripple voltage due to reactance. This is in addition to the ripple caused by capacitor ESR. Physically larger input capacitors will have more capacitance (less reactance) and lower ESR. Small voltage dips during switch ON time are not normally a problem, but at very low input voltage they may cause erratic operation because the input voltage drops below the minimum specification. Problems can also occur if the input to output voltage differential is near minimum.

Minimum Input Voltage (After Start-Up)

Minimum input voltage to make the LT1507 “run” correctly is typically 3.6V, but to regulate the output, a buck converter input voltage must always be higher than the output voltage. To calculate minimum operating input voltage, switch voltage loss and maximum duty cycle must be taken into account. With the LT1507 there is the additional consideration of proper operation of the boost circuit. The boost circuit allows the power switch to saturate for high efficiency, but it also sometimes results in a start-up or low current operating voltage that is 0.5V

to 1.5V higher than the standard running voltage, especially at light loads. An approximate formula to calculate minimum *running* voltage at load currents *above 100mA* is:

$$V_{IN(MIN)} = \frac{V_{OUT} + (I_{OUT})(0.3\Omega)}{0.85} \quad (I_{OUT} \geq 100mA)$$

With $V_{OUT} = 3.3V$ and $I_{OUT} = 0.1A$, this formula yields $V_{IN(MIN)} = 3.9V$. Increasing load current to 1A raises minimum input to 4.2V. For start-up and operation at light loads, see the next section.

Minimum Start-Up Voltage and Operation at Light Loads

The boost capacitor supplies current to the BOOST pin during switch ON time. This capacitor is recharged only during switch OFF time. Under certain conditions of light load and low input voltage, the capacitor may not be fully recharged during the relatively short OFF time. This causes the boost voltage to collapse and minimum input voltage is increased. Start-up voltage at light loads is higher than normal running voltage for the same reasons. Figure 5 shows minimum input voltage for a 3.3V output, both for start-up and for normal operation. This graph indicates that a 5V to 3.3V converter with 4.7V minimum input voltage, will not start correctly below a 40mA load current and will not run correctly below a 4mA load current. If minimum load current is less than 50mA, a preload should be added or the circuit in Figure 6 can be used.

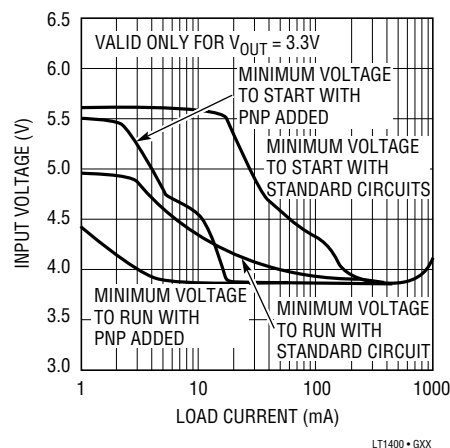

Figure 5. Minimum Input Voltage for $V_{OUT} = 3.3V$

APPLICATIONS INFORMATION

The circuit in Figure 6 will allow operation at light loads with low input voltages. It uses a small PNP to charge the boost capacitor (C2) and an extra diode (D3) to complete the power path from V_{SW} to the boost capacitor. Note that the diodes have been changed to Schottky BAT85s to optimize low voltage operation. Figure 5 shows that with the added PNP, minimum load current can be reduced to 6mA and still guarantee proper start-up with 4.7V input.

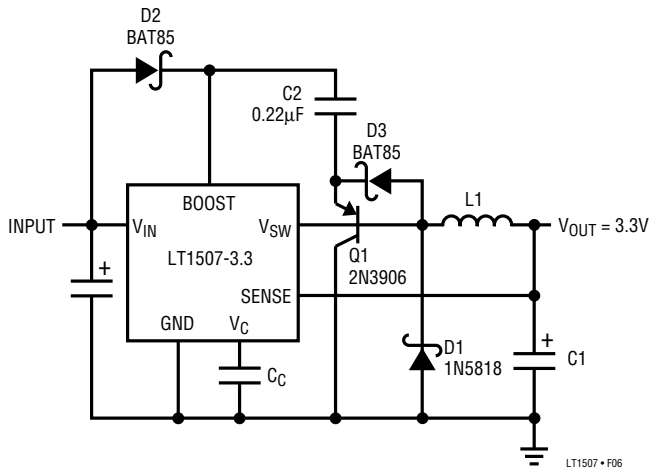

Figure 6. Adding a Small PNP to Reduce Minimum Start-Up Voltage

SYNCHRONIZING

The LT1507 SYNC pin is used to synchronize the internal oscillator to an external signal. It is directly logic compatible and can be driven with any signal between 10% and 90% duty cycle. The synchronizing range is equal to *initial* operating frequency up to 1MHz (above 700kHz external slope compensation may be needed). This means that minimum practical sync frequency is equal to the worst-case *high* self-oscillating frequency (560kHz) not the typical operating frequency of 500kHz. Caution should be used when synchronizing above 700kHz because at higher sync frequencies, the amplitude of the internal slope compensation used to prevent subharmonic switching is reduced. This type of subharmonic switching only occurs at input voltages less than twice the output voltage and shows up as alternating pulse widths at the switch node. It does not cause the regulator to lose regulation, but switch frequency content down to 100kHz may be objectionable. Higher inductor values will tend to eliminate

problems. For low input voltage, high sync frequency applications, the circuit shown in Figure 7 can be used to generate an external slope compensation ramp that eliminates subharmonic oscillation. See Frequency Compensation section for a discussion of an entirely different cause of subharmonic switching before assuming that the cause is insufficient slope compensation. Application Note 19 has more details on the theory of slope compensation.

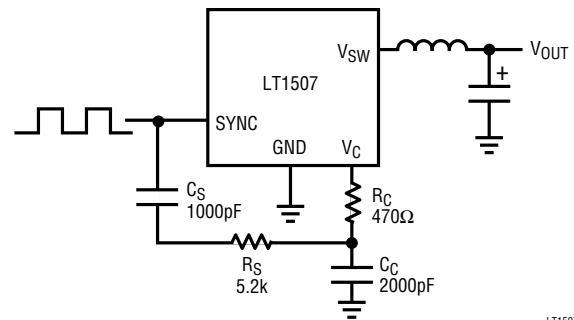

Figure 7. Adding External Slope Compensation for High Sync Frequencies

External Slope Compensation Ramp

The LT1507 is a current mode switching regulator and therefore, it requires something called “slope compensation” *when operated above 50% duty cycle in continuous mode*. This condition occurs when input voltage is less than twice output voltage. Slope compensation adds a ramp to the switch current sense signal generated on the chip during switch ON time. Typically the ramp is generated from a portion of the internal oscillator waveform. In the LT1507, the ramp is arranged to be zero until the oscillator waveform reaches about 40% of its final value. This minimizes the total amount of ramp added to switch current. The reason for doing it this way is that the ramp subtracts from switch current limit, so that switch current limit would be considerably lower at high duty cycle compared to low duty cycle if the ramp existed at all duty cycles. By starting the ramp at the 40% point, changes in current limit are minimized. No ramp is needed when operating below 50% duty cycle.

Problems can occur with this technique if the regulator is used with a combination of high external sync frequency and more than 50% duty cycle. The basic sync function

APPLICATIONS INFORMATION

works by prematurely tripping the oscillator before it reaches its normal peak value. For instance, if the oscillator is synchronized at twice its nominal frequency, oscillator amplitude will drop by half. A ramp which previously started at the 40% point now starts at the 80% point! This effectively blocks slope compensation and the regulator may respond with fluctuating pulse widths, a “phase oscillation” if you will. The regulator output stays in regulation but subharmonic frequencies are generated at the switch node.

The solution to this problem is to generate an external ramp that replaces the missing internal ramp. As it turns out, this is not difficult if the sync signal can be arranged to have a fairly low duty cycle (< 35%). The ramp is created by AC coupling a resistor from the sync signal to the compensation capacitor as shown in Figure 7. This generates a negative ramp on the V_C pin during switch ON time that emulates the missing internally generated ramp. Amplitude of the ramp should be about 100mV to 200mV peak-to-peak. The formulas for calculating the values of R_S and C_S are shown below. Note that the C_S value is unimportant as long as it exceeds the value given. The formula assures that the impedance of C_S will be small compared to R_S .

$$R_S = \frac{V_{\text{SYNC}}(DC_S)(1 - DC_S)}{V_{\text{P-P}}(C_C)(f)}$$

$$C_S > \frac{20}{2\pi(f)(R_S)}$$

V_{SYNC} = Peak-to-peak value of sync signal

DC_S = Duty cycle of incoming sync signal

$V_{\text{P-P}}$ = Desired amplitude of ramp

f = Sync frequency

Theoretical minimum amplitude for the ramp, assuming no internal ramp, is:

$$V_{\text{P-P}} \geq \frac{(2V_{\text{OUT}} - V_{\text{IN}})(1 - DC_S)}{2(f)(L)(g_{\text{mP}})}$$

g_{mP} = Transconductance from V_C pin to switch current (1.8A/V for the LT1507).

For $V_{\text{IN}} = 4.7$, $V_{\text{OUT}} = 3.3\text{V}$, $f = 1\text{MHz}$, $L = 5\mu\text{H}$ and $DC_S = 25\%$:

$$V_{\text{P-P}} \geq \frac{(6.6 - 4.7)(1 - 0.25)}{2 \left[1(10^6) \right] \left[5(10^{-6}) \right] 1.8} = 71\text{mV}$$

To avoid small values of R_S , the compensation capacitor (C_C) should be made as small as possible. 2000pF will work in most situations. If we increase V_{PP} to 90mV for a little cushion, R_S will be:

$$R_S = \frac{(5)(0.25)(0.75)}{0.09 \left[2(10^{-9}) \right] \left[1(10^6) \right]} = 5.2\text{k}$$

$$C \geq \frac{20}{2\pi \left[1(10^6) \right] (5200)} = 612\text{pF}$$

THERMAL CALCULATIONS

Power dissipation in the LT1507 chip comes from four sources: switch DC loss, switch AC loss, boost circuit current and input quiescent current. The formulas below show how to calculate each of these losses. These formulas assume continuous mode operation, so they should not be used for calculating efficiency at light load currents.

Switch loss:

$$P_{\text{SW}} = \frac{R_{\text{SW}}(I_{\text{OUT}})^2(V_{\text{OUT}})}{V_{\text{IN}}} + 16\text{ns}(I_{\text{OUT}})(V_{\text{IN}})(f)$$

Boost current loss:

$$P_{\text{BOOST}} = \frac{V_{\text{OUT}}^2}{V_{\text{IN}}} \left(0.008 + \frac{I_{\text{OUT}}}{75} \right)$$

Quiescent current loss:

$$P_Q = V_{\text{IN}}(0.003) + V_{\text{OUT}}(0.005)$$

R_{SW} = Switch resistance ($\approx 0.4\Omega$)

16ns = Equivalent switch current/voltage overlap time

f = Switching frequency

APPLICATIONS INFORMATION

Example: with $V_{IN} = 5V$, $V_{OUT} = 3.3V$, $I_{OUT} = 1A$;

$$P_{SW} = \frac{(0.4)(1)^2(3.3)}{5} + [16(10^{-9})](1)(5)[500(10^3)]$$

$$= 0.26 + 0.04 = 0.3W$$

$$P_{BOOST} = \frac{(3.3)^2}{5} \left(0.008 + \frac{1}{75} \right) = 0.046W$$

$$P_Q = 5(0.003) + 3.3(0.005) = 0.032W$$

Total power dissipation is $0.3 + 0.046 + 0.032 = 0.38W$.

Thermal resistance for the LT1507 packages is influenced by the presence of internal or backside planes. With a full plane under the SO package, thermal resistance will be about $120^{\circ}C/W$. No plane will increase resistance to about $150^{\circ}C/W$. To calculate die temperature, use the proper thermal resistance number for the desired package and add in worst-case ambient temperature;

$$T_J = T_A + \theta_{JA}(P_{TOT})$$

With the S8 package ($\theta_{JA} = 120^{\circ}C/W$) at an ambient temperature of $70^{\circ}C$;

$$T_J = 70 + 120(0.38) = 116^{\circ}C$$

FREQUENCY COMPENSATION

The LT1507 uses a “current mode” architecture to help alleviate phase shift created by the inductor. The basic connections are shown in Figure 9. Gain of the power stage can be modeled as $1.8A/V$ transconductance from the V_C pin voltage to current delivered to the output. This is shown in Figure 8 where the transconductance from V_C pin to inductor current is essentially flat from 50Hz to 50kHz and phase shift is minimal in the important loop unity-gain band of 1kHz to 50kHz. Inductor variation from $3\mu H$ to $20\mu H$ will have very little effect on these curves.

Overall gain from the V_C pin to output is then modeled as the product of $1.8A/V$ transconductance multiplied by the complex impedance of the load in parallel with the output capacitor model.

The error amplifier can be modeled as a transconductance of $2000\mu mho$, with an output impedance of $200k\Omega$ in

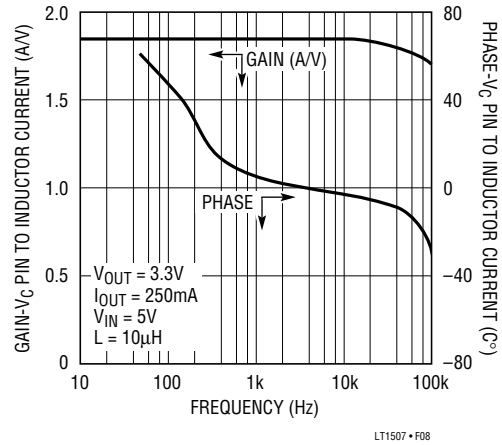

Figure 8. Phase and Gain from V_C Pin Voltage to Inductor Current

parallel with $12pF$. In all practical applications, the compensation network from V_C pin to ground has a much lower impedance than the output impedance of the amplifier at frequencies above 500Hz. This means that the error amplifier characteristics themselves do not contribute excess phase shift to the loop and the phase/gain characteristics of the error amplifier section are completely controlled by the external compensation network.

The complete small-signal model is shown in Figure 9. R_1 and R_2 are the divider used to set output voltage. These are internal on the fixed voltage LT1507-3.3 with $R_1 = 1.8k$ and $R_2 = 5k$. R_C , C_C and C_F are external compensation

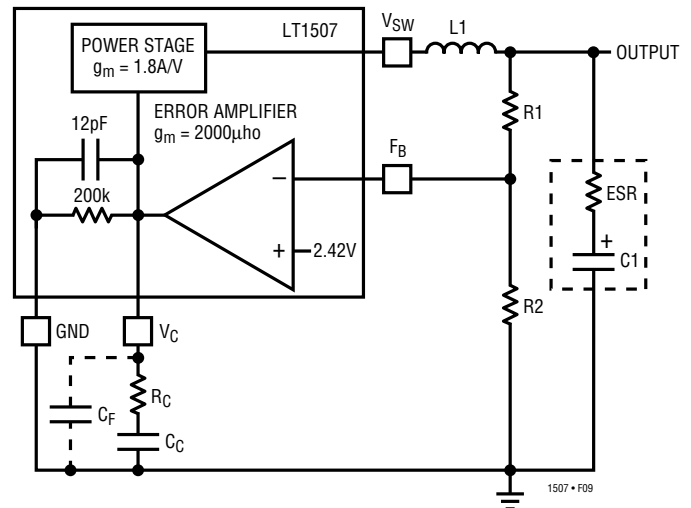

Figure 9. Small-Signal Model for Loop Stability Analysis

APPLICATIONS INFORMATION

components. In many cases only C_C is needed. Adding R_C will improve phase margin, but this may necessitate the need for C_F to limit switching frequency ripple at the V_C pin.

In Figure 10, full loop phase/gain characteristics are shown with a compensation capacitor (C_C) of $0.0033\mu\text{F}$, giving the error amplifier a pole at 240Hz, with phase rolling off to 90° and staying there. The overall loop has a gain of 77dB at low frequency rolling off to unity gain at 20kHz. Phase shows a 2-pole characteristic until the ESR of the output capacitor brings it back above 10kHz. Phase margin is about 60° at unity-gain.

Analog experts will note that around 1kHz, phase dips to within 20° of the zero phase margin line. This is typical of switching regulators because of the 2-pole rolloff generated by the output capacitor and the compensation network. This region of low phase is not a problem as long as it does not occur near unity-gain. In practice, the variability of output capacitor ESR tends to dominate all other effects with respect to loop response. Variations in ESR *will* cause unity-gain to

move around, but at the same time phase moves with it so that adequate phase margin is maintained over a very wide range of ESR ($\geq 5:1$)

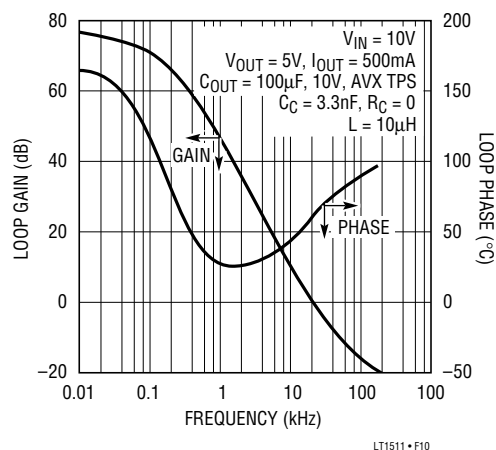

Figure 10. Overall Loop Phase and Gain

Undervoltage Lockout

See Application Information in LT1376 data sheet.

PACKAGE DESCRIPTION

Dimensions in inches (millimeters) unless otherwise noted.

N8 Package 8-Lead PDIP (Narrow 0.300) (LTC DWG # 05-08-1510)

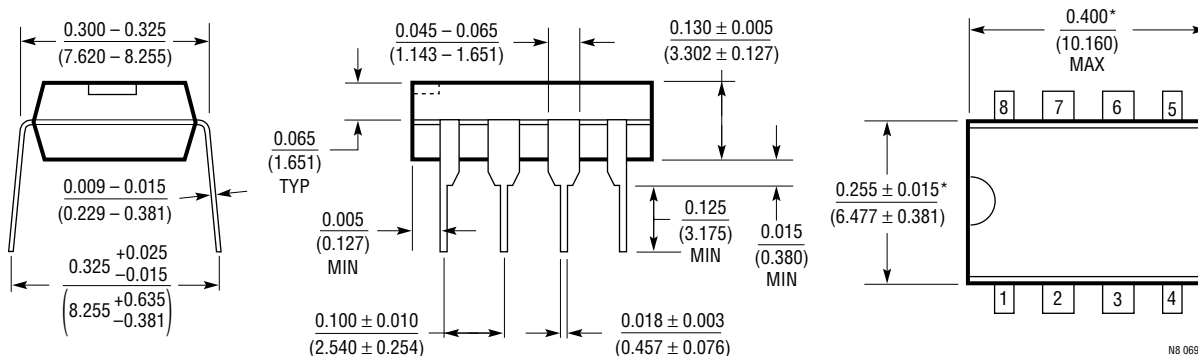

*THESE DIMENSIONS DO NOT INCLUDE MOLD FLASH OR PROTRUSIONS.
MOLD FLASH OR PROTRUSIONS SHALL NOT EXCEED 0.010 INCH (0.254mm)

PACKAGE DESCRIPTION Dimensions in inches (millimeters) unless otherwise noted.

S8 Package
8-Lead Plastic Small Outline (Narrow 0.150)
 (LTC DWG # 05-08-1610)

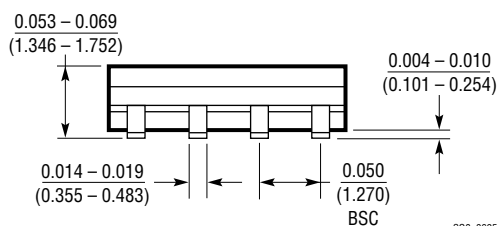
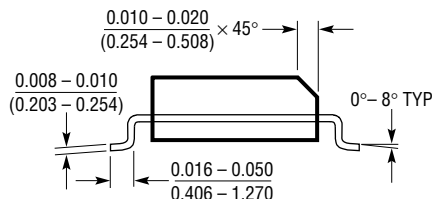
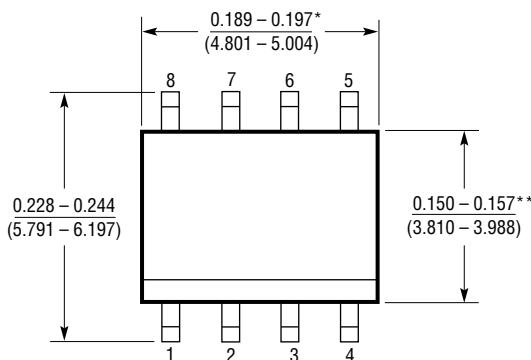

DIMENSION DOES NOT INCLUDE MOLD FLASH. MOLD FLASH SHALL NOT EXCEED 0.006 (0.152mm) PER SIDE
 **DIMENSION DOES NOT INCLUDE INTERLEAD FLASH. INTERLEAD FLASH SHALL NOT EXCEED 0.010* (0.254mm) PER SIDE

RELATED PARTS

PART NUMBER	DESCRIPTION	COMMENTS
LT1371	3A 500kHz Step-Up Switching Regulator	High Current DC/DC Conversion Uses Small Power Components
LT1372	1.5A 500kHz Step-Up Switching Regulator	Includes Positive and Negative Output Voltage Regulation
LT1375	1.5A 500kHz Step-Down Switching Regulator	Includes Synchronization Capability
LT1376	1.5A 500kHz Step-Down Switching Regulator	Output Biasing Yields 90% Efficiency
LT1377	1.5A 1MHz Step-Up Switching Regulator	Highest Frequency Monolithic Switching Regulator